



# MANDARIN IMPORTS AND EXPORTS



## Forklift Attachments Catalogue

---

**P2:** Extension Slippers

**P3:** Container Ramps

**P4:** Safety Cage

**P4:** Goods Cage

**P5:** Fixed Short Forklift Jib

**P6:** Fixed Long Forklift Jib

**P7:** Tilted Forklift Jib

**P8:** Forklift Lifting Hooks/Crane

**P9:** Tow Bar forklift Jib

**P10:** Single Drum Lifters

**P11:** Mounted/Slip on Roll Prong

**P12:** Tyres

**P13:** Side Shift/Load Guard

**P14:** Tynes/Forks

**P15:** Rotators

**P15:** Forward Bulk Bin Tipper

**P16:** Hand Pallet Jack



50 Mandarin Street, Fairfield East NSW 2165

02 9727 0753 | [Serene@mandarinimportsexports.com.au](mailto:Serene@mandarinimportsexports.com.au)

[mandarinimportsexports.com.au](http://mandarinimportsexports.com.au)

# Extension Slippers

Attachments designed to extend the length of forklift tynes, enabling them to handle larger, longer, or more awkward loads safely. These extensions simply slide onto the existing tynes and are secured with a safety pin for stability.



Type	Class	Length	Max Tyne fitting	Weight	Safe Working Load
TE1-18	1	1800mm	100X45mm	55kg	3000kg
TE1-21	1	2100mm	100X45mm	65kg	3000kg
TE1-24	1	2400mm	100X45mm	75kg	3000kg
TE2-16	2	1600mm	130x50mm	59kg	4500kg
TE2-18	2	1800mm	130x50mm	66kg	4500kg
TE2-21	2	2100mm	130x50mm	77kg	4500kg
TE2-24	2	2400mm	130x50mm	88kg	4500kg
TE3-18	3	1800mm	150x60mm	102kg	6500kg
TE3-21	3	2100mm	150x60mm	119kg	6500kg
TE3-24	3	2400mm	150x60mm	136kg	6500kg
TE3-30	3	3000mm	150x60mm	170kg	6500kg
TE3-35	3	3500mm	150x60mm	202kg	6500kg
TE4-18	4	1800mm	165x65mm	112kg	8500kg
TE4-21	4	2100mm	165x65mm	132kg	8500kg
TE4-24	4	2400mm	165x65mm	152kg	8500kg
TE4-30	4	3000mm	165x65mm	260kg	8500kg
TE4-35	4	3500mm	165x65mm	300kg	8500kg

# Container Ramps

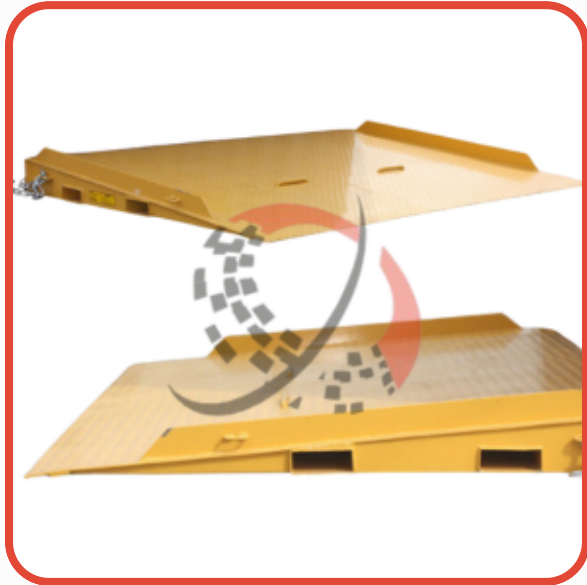

## Container Ramp w Raised Side Plates & Pocket

is designed for fast positioning and removal. Fitted with pockets each side, plus flip-up front tine pockets, this ramp can be maneuvered in confined spaces. Raised side plates ensure the Forklift remains on the ramp.

Model	CRS8
Load Capacity	8000
Weight	440kg
Width	2320mm
Length	1800mm

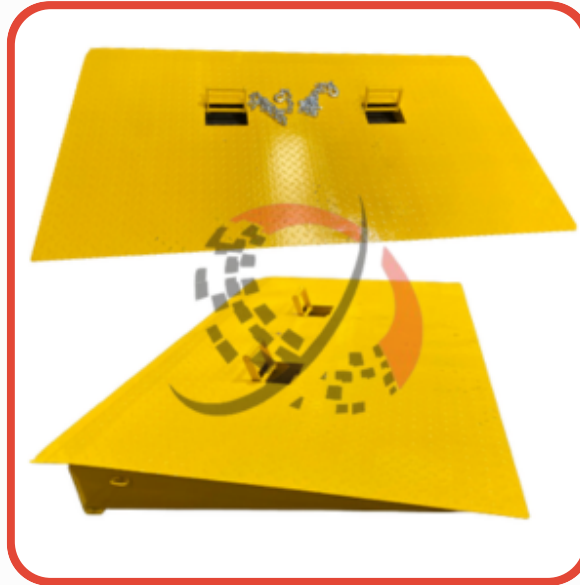

## Container Ramp with Top Loading Pockets

is a highly versatile and practical tool for loading and unloading goods from shipping containers. They're designed with pockets at the top, which allow for easy handling and placement using a forklift.

Model	CR60	CR65
Load Capacity	6000	6500
Weight	160kg	180kg
Width	2000mm	2200mm
Length	1250mm	1542mm



## Foldable Container Ramp

is highly portable and easy to store, offering a great advantage in spaces where storage is limited. These ramps are typically sturdy, designed to bear heavy loads, making them perfect for industrial or commercial applications.

Model	CR70
Load Capacity	7000
Weight	340kg
Width	2200mm
Length	2000mm

# Safety / Goods Cage



## Safety Cage / Work Platform

Designed for short-term maintenance tasks where safety at height is key, features a self-closing inward gate and two floor-mounted harness anchor points. For added convenience and safety, it comes with a removable tray for tool placement.

Model	SC10
Safe Working load	250kg
Load Centre	600mm
Unit Weight	122kg
Dimensions	1040x1070x2080

Note: Don't use this work platform on a forklift if its capacity is less than 1860kg for counterbalance, or 1116kg for reach types.

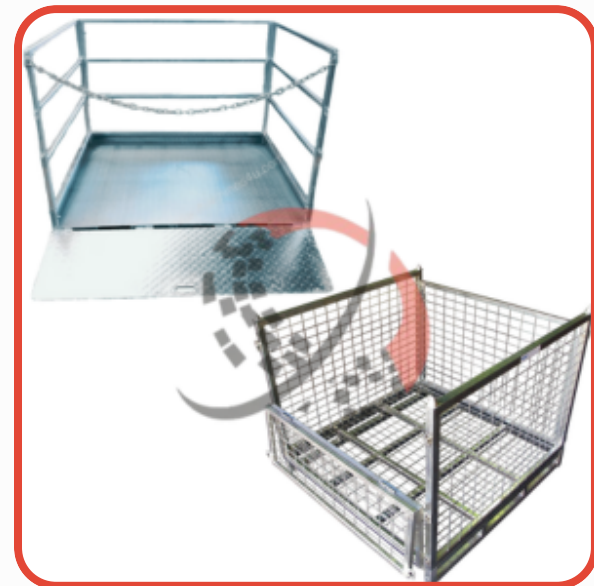

## Goods Cages

Meticulously crafted to ensure secure storage and effortless transportation of items, ranging from furniture to whitegoods. Our goods cages come in two different designs.

Model	CG15	CG20
Safe Working load	1500kg	2000kg
Load Centre	600mm	600mm
Unit Weight	143kg	65kg
Dimensions	1150x1150x1200	1160x1160x990

# Fixed Short Forklift Jib

This jib acts as a compact extension arm, transforming the forklift into a makeshift crane, enabling easy lifting and precise placement of items. Ideal for warehouses, construction sites, or any location that requires the movement of heavy or bulky goods.

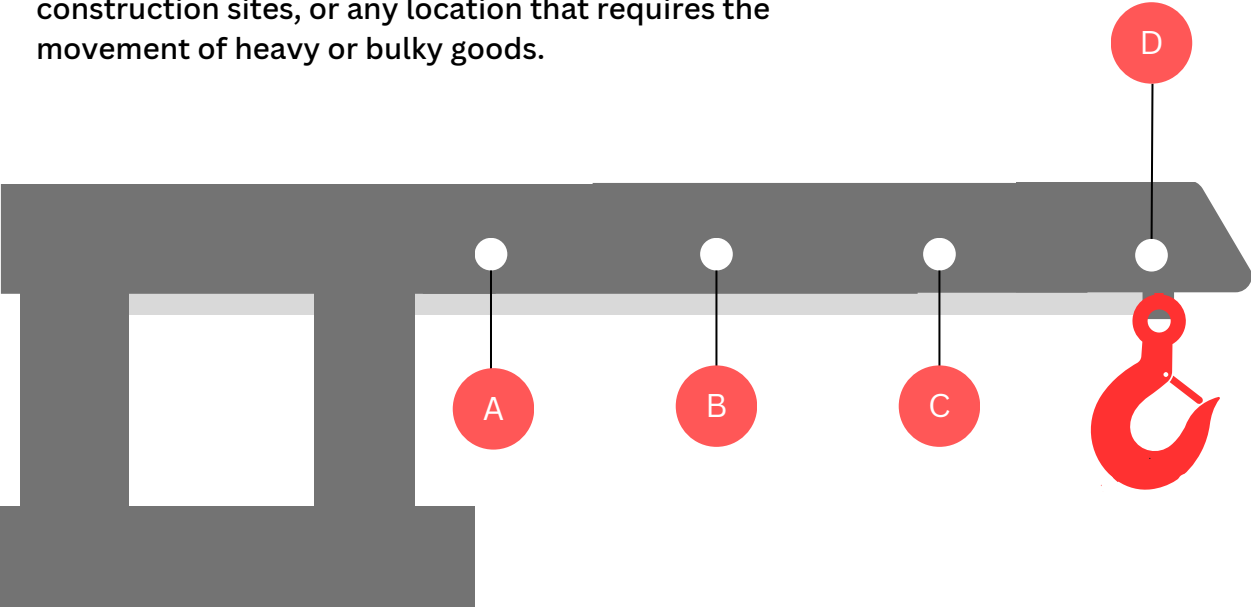

\*Diagram not to exact scale. Refer to the table below for measurements:

Model	Weight	Load Centre	Pocket Size	POSITION	A	B	C	D
FSJ2.5	100kg	790mm	185x65mm	<b>Extension (mm)</b> <b>Safe Working Load (kg)</b>	790mm (2500kg)	1200mm (1200kg)	1580mm (900kg)	1960mm (750kg)
FSJ5.0	130kg	790mm	200x100mm		780mm (4750kg)	1200mm (2400kg)	1580mm (1800kg)	1960mm (1500kg)
FSJ7.5	320kg	930mm	180x80mm		930mm (7500kg)	1245mm (3600kg)	1625mm (2700kg)	2005mm (2250kg)
FSJ10	400kg	930mm	230x110mm		930mm (10000kg)	1245mm (4800kg)	1625mm (3600kg)	2005mm (3000kg)

# Fixed Long Forklift Jib

A highly useful attachment that significantly extends the versatility of a standard forklift. Designed to handle long, awkward loads, this jib transforms a forklift into a makeshift crane, allowing the operator to reach over obstacles or lift objects from hard-to-reach places.

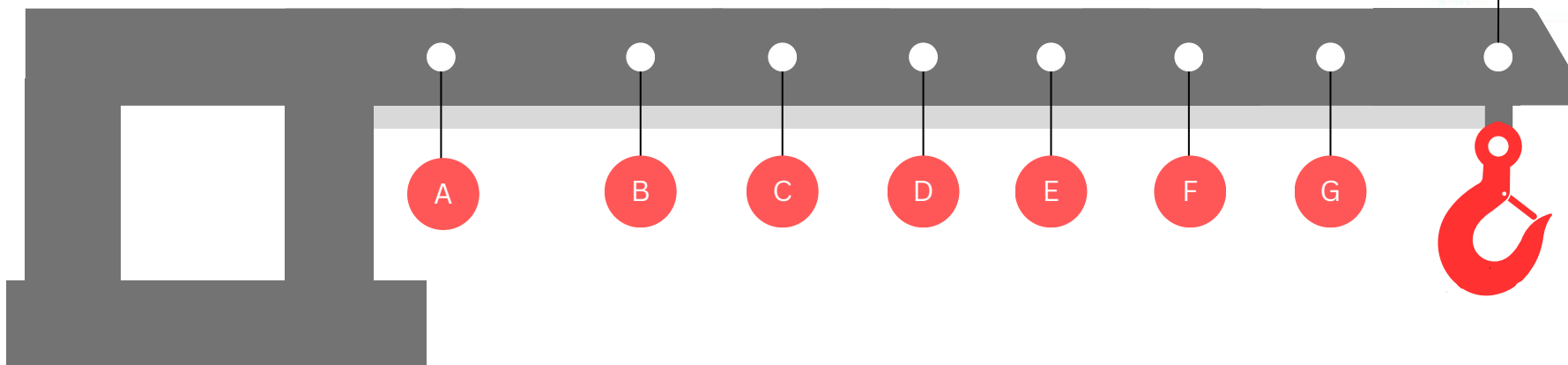
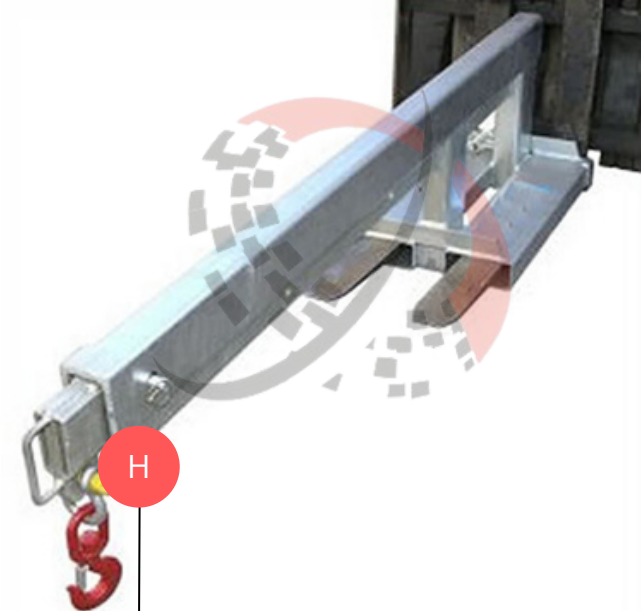

\*Diagram not to exact scale. Refer to the table below for measurements:

Model	Weight	Load Centre	Pocket Size	POSITION	A	B	C	D	E	F	G	H
FLJ2.5	168kg	790mm	185x75mm	<b>Extension (mm)</b> <b>Safe Working Load (kg)</b>	950mm (2500kg)	1410mm (2500kg)	1870mm (1900kg)	2000mm (1650kg)	2380mm (1250kg)	2760mm (650kg)	3140mm (380kg)	3520mm (240kg)
FLJ5.0	180kg	920mm	200x100mm		935mm (4750kg)	1395mm (4275kg)	1855mm (3800kg)	2000mm (3300kg)	2380mm (2500kg)	2760mm (1300kg)	3140mm (760kg)	3520mm (480kg)
FLJ7.5	450kg	920mm	180x80mm		920mm (7500kg)	1380mm (6410kg)	1805mm (5700kg)	2045mm (4950kg)	2425mm (3750kg)	2805mm (1950kg)	3185mm (1140kg)	3565mm (720kg)
FLJ10	515kg	920mm	230x110mm		920mm (10000kg)	1380mm (8550kg)	1805mm (7600kg)	2045mm (6600kg)	2425mm (5000kg)	2805mm (2600kg)	3185mm (1520kg)	3565mm (960kg)

# Tilted Forklift Jib

This jib can be tilted at various angles, making it ideal for lifting and moving items at heights or in spaces where a straight lift would not be possible. It essentially transforms your forklift into a versatile crane, capable of reaching over obstacles or accessing hard-to-reach spots.



Tilt Angle	0 Degrees	15 Degrees	30 Degrees	45 Degrees
<b>Lifting Height (mm)</b>				
TLJ2.5	405	1190	1910	2400
TLJ5.0	470	1170	1825	2400
TSJ5.0	472	795	1095	1360

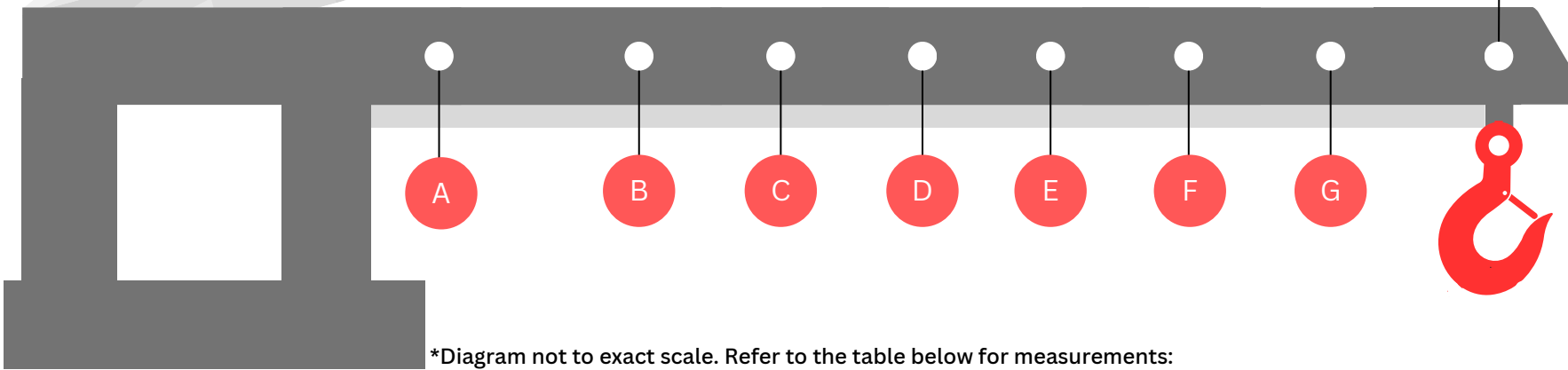

\*Diagram not to exact scale. Refer to the table below for measurements:

Model	Weight	Load Centre	Pocket Size	POSITION	A	B	C	D	E	F	G	H
TLJ2.5	196kg	790mm	185x75mm	<b>Extension (mm)</b> <b>Safe Working Load (kg)</b>	1005mm (2500kg)	1465mm (2500kg)	1925mm (1900kg)	2060mm (1650kg)	2440mm (1250kg)	2820mm (650kg)	3200mm (380kg)	3580mm (240kg)
TLJ5.0	240kg	920mm	200x100mm		1000mm (4750kg)	1460mm (4275kg)	1920mm (3800kg)	2070mm (3300kg)	2450mm (2500kg)	2830mm (1300kg)	3210mm (760kg)	3590mm (480kg)
TSJ5.0	180kg	920mm	185x75mm		920mm (4750kg)	1120mm (3600kg)	1270mm (2400kg)	1650mm (1800kg)	2030mm (1500kg)	N/A	N/A	<b>Z</b>

# Forklift Lifting Hooks/Crane

This attachment converts your forklift into an improvised crane, allowing it to lift, carry, and place loads that would otherwise be impossible to manage. They provide a secure point to attach slings, chains, or other lifting equipment.

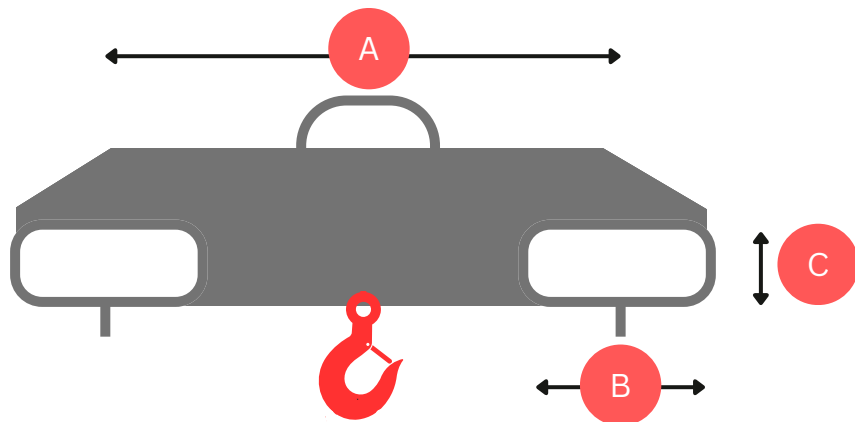
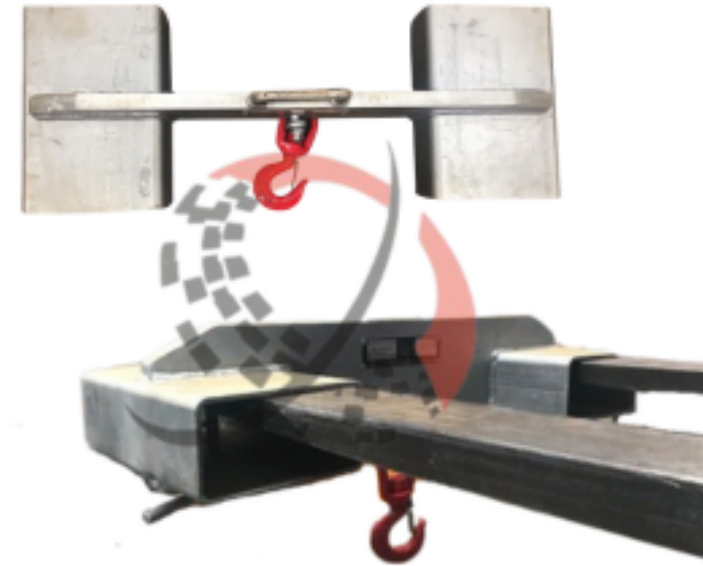

- ✓ **Mounted on Forklift tyres with two locking screws**
- ✓ **Supplied with swivel hook and alloy shackle**
- ✓ **Surface treatment: Galvanized finish**

\*Diagram not to exact scale. Refer to the table below for measurements:

Model	A	B	C	Safe Working Load	Pocket Size	Unit Weight
CH2.0	600mm	188mm	88mm	2000kg	188x88mm	30kg



# Tow Bar forklift Jib

A Tow Bar Forklift Jib Attachment is a versatile tool that expands the capabilities of a standard forklift, transforming it into a towing vehicle. This attachment allows the forklift to pull or tow heavy loads that are otherwise challenging to move.

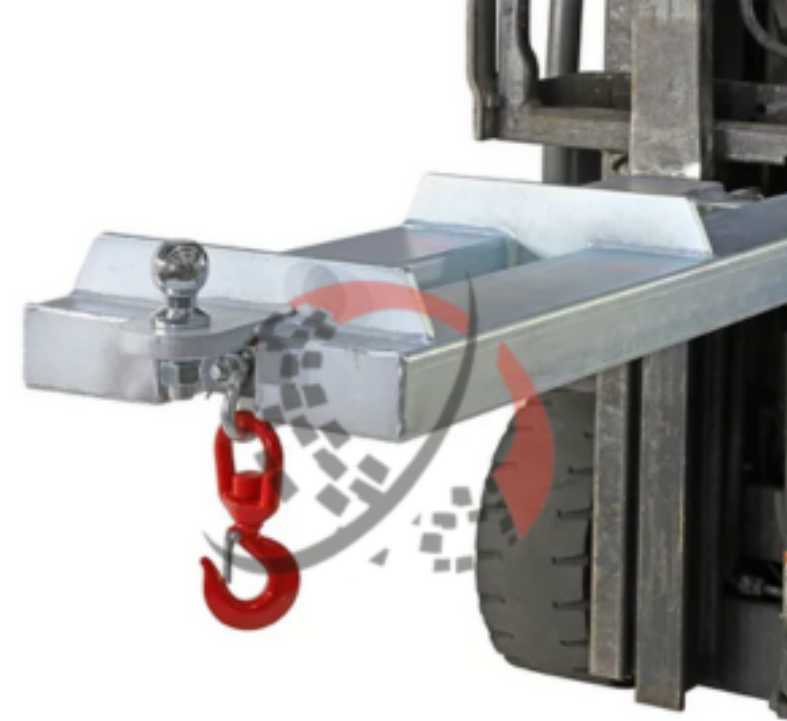
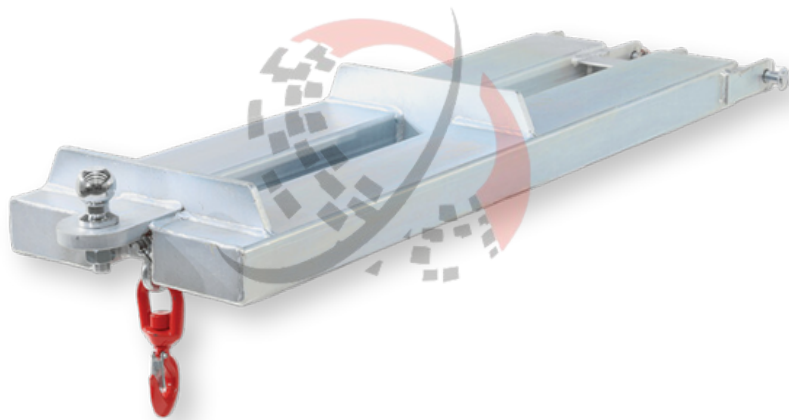

- ✔ **Supplied with swivel hook and alloy shackle**
- ✔ **Surface treatment: Galvanized finish**

Maximum weight on tow ball must not exceed 500kg

Model	Safe Working Load	Pocket Size	Unit Weight	Fork Pocket Length
CH2.0	2000kg at 1160mm Load Centre	140x65mm	45kg	1220mm

# Single Drum Lifters

---

With its high clamping force, this attachment ensures a secure handling of drums even on uneven terrain. It is compatible with standard 205-litre steel drums and some plastic variants, making it versatile and adaptable for various industrial needs.

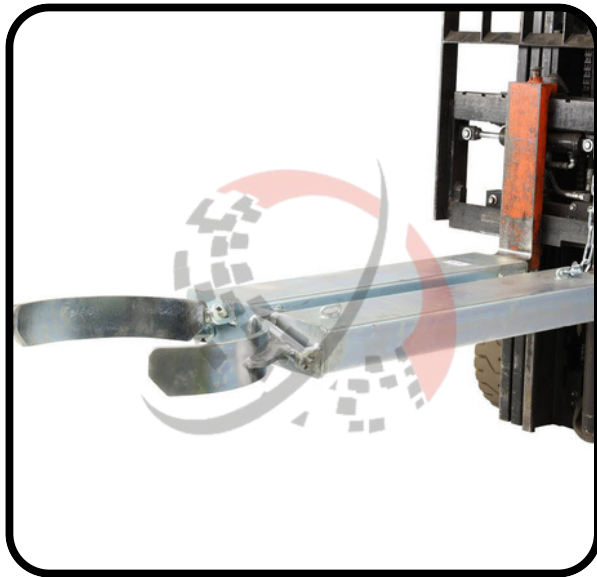

<b>Model</b>	<b>BGN1</b>
<b>Safe Working Load</b>	1000kg
<b>Fork Pocket Center</b>	250mm
<b>Fork Pocket Size</b>	185x60mm
<b>Load Centre</b>	1210mm
<b>Unit Weight</b>	72kg

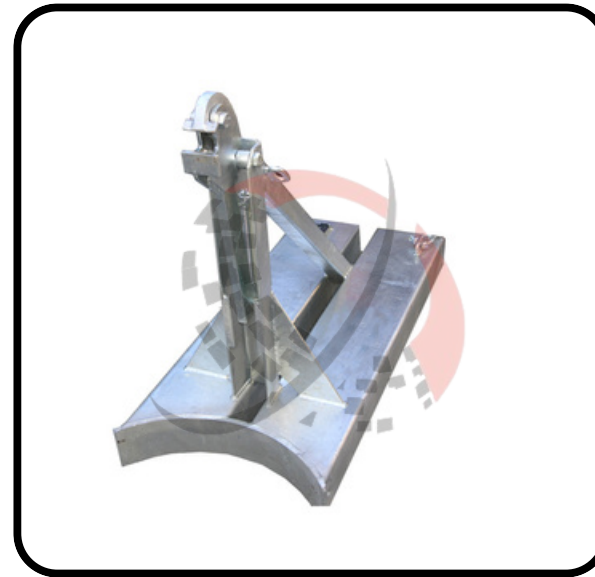

<b>Model</b>	<b>SDL1</b>
<b>Safe Working Load</b>	500kg
<b>Fork Pocket Center</b>	300mm
<b>Fork Pocket Size</b>	185x65mm
<b>Load Centre</b>	1340mm
<b>Unit Weight</b>	74kg

# Mounted Roll Prong/Carpet Pole

A vital attachment used in the material handling and warehousing industry. This device is designed to safely and efficiently transport rolls of carpet, fabric, or similar materials without causing any damage.

Model	Prong Length	Safe Working Load	Weight	Load Centre	Class	Diameter
RPC-QR2	2800mm	850kg	166kg	1400mm	2	80mm
RPC-QR3	2800mm	580kg	220kg	1400mm	3	80mm

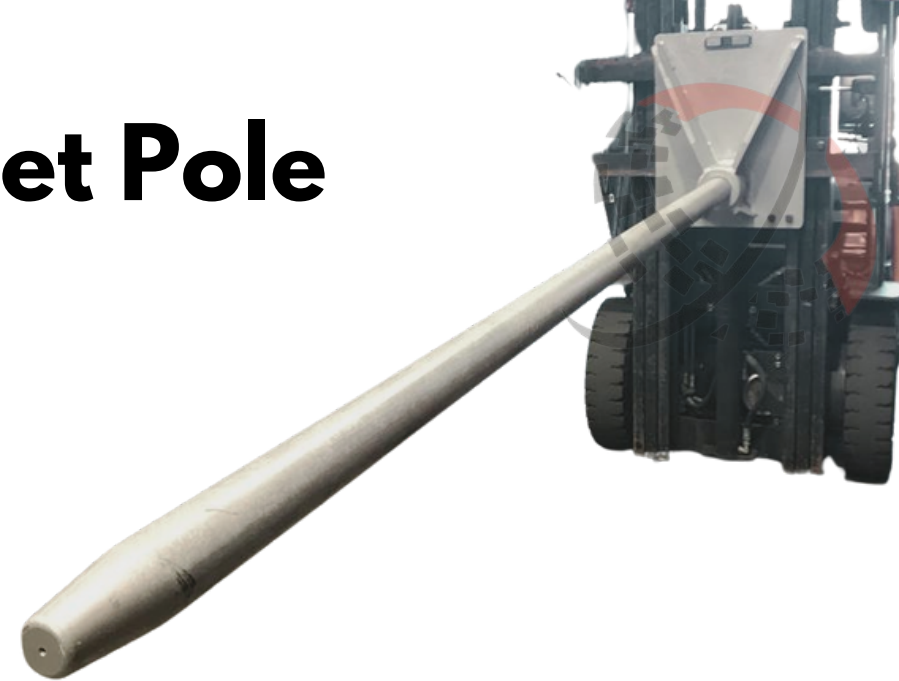

# Slip on Roll Prong/Carpet Pole



Model	Prong Length	Safe Working Load	Weight	Load Centre	Class	Diameter
RPS-2N-40-1200	1200mm	200kg	91kg	600mm	2	40mm
RPS-2N-50-1800	1800mm	250kg	106kg	900mm	2	50mm
RPS-2N-60-2800	2800mm	340kg	141kg	1400mm	2	60mm
RPS-2N-70-2800	2800mm	510kg	163kg	1400mm	2	70mm
RPS-2N-80-2800	2800mm	850kg	194kg	1400mm	2	80mm
RPS-3N-100-2800	2800mm	1700kg	328kg	1400mm	3	100mm

# Tyres

Our solid tyres, featuring cutting-edge design and technology, optimizes performance for medium to high-intensity warehousing applications.

- ✔ **Enhanced efficiency and safety for your team**
- ✔ **Longer lasting tyres with advanced three-compound design**
- ✔ **Resilient against wear and tear, minimizing costly replacements**
- ✔ **Provides excellent value with competitive pricing without sacrificing quality**
- ✔ **Smoother rides and improved stability during operations for a safer work environment**

\*Not all sizes listed above, please contact us if you cannot find required size.

Wheels	Machine	Tyre/Rim Colour
500x8/3.00		White/Black
650x10/5.00		White/Black
600x9/4.00		White/Black
700x12/5.00 (≤2.5t forklift)	NISSAN/ YALE	White/Black
700x12/5.00 (≤2.5t forklift)	TOYOTA	White/Black
500x8/3.00		Black/Black
600x9/4.00		Black/Black
650x10/5.00		Black/Black
700x12/5.00 (≤2.5t forklift)	NISSAN/ YALE	Black/Black
700x12/5.00 (≤2.5t forklift)	TOYOTA	Black/Black

Solid Tyres	Colour
300x15/8.00	Black
250x15/7.00	Black
250x15/7.00 click clock	Black
21x8-9/6.00 click clock	Black
16x6-8/4.33	Black
18x7-8/4.33 (>2T forklift)	Black
28x9-15/7.00	Black
300x15/8.00	White

Solid Tyres	Machine	Tyre/Rim Colour
323X100	JLG 1930ES	Grey/White
406X125	JLG2646ES/ 2630ES/JLG3246ES	Grey/White
16X5X12	SKYJACK3226/4632	Grey/White
200x8 (12x4)	SKYJACK-3219	Grey/White



# Side Shift w Load Guard

---

Our range of side shifts allow lateral movement of the load, enabling the forklift operator to place the load in the correct position without various movements of the forklift truck. All side shifts come with load guards.

Model	Capacity/Load Centre	Class	Carriage Width
CP-CY25D01B	2500KGS@600mm	2	1020mm
CP-CY35D01B	3500KGS@600mm	2	1070mm
SSS70D-001C-1190	6800kg@600mm	4	1190mm
SSS70D-001C-1840	6800kg@600mm	4	1840mm
SSS70D-001C-2300	6800kg@600mm	4	2300mm



## Load Guard Only

---

Model	Dimensions	Class
LG1020	1020mm x 850mm	2
LG920	920mm x 850mm	2
LG1070	1070mmx850mm	3

# Tynes/Forks

A key component of a forklift that are used to lift and transport materials. The size, thickness, and spacing of the tynes can vary depending on load requirements.



note: not all sizes listed above, please contact us if you cannot find required size

Mounting Class	Weight per pair (kg)	Width x Thickness x Length
2	105	100X40X1070
2	112	100X45X1220
2	110	120X40X1070
2	124	120X40X1220
2	150	120X40X1530
2	168	120X40X1820
2	200	120X40X2100
2	220	120X40X2400
3	125	125X45X1070
3	146	125X45X1200
3	180	125X45X1520
3	200	125X45X1820
3	250	125X50X2200
3	320	125X50X2400
3	346	150X50X2400
3	450	125X50X3000
3	500	150X50X3000
4	348	150X60X1220
4	368	150X60X1520
4	380	150X60X1820
4	400	150X60X2120
4	432	150X60X2400
4	348	150X60X3000
4	404	150X70X1820
4	452	150X70X2120
4	502	150X70X2400

# Hydraulic 360 Degree Rotators

Our range of 360° Rotators increases forklift functionality by enabling the operator to rotate loads and empty bins, while retaining the ability to handle palletized and conventional loads.

Model	Capacity/Load Centre	Class	Carriage Width
CP-XQ25G01B	2500KGS@500mm	2	1020mm
CP-XQ30G01B	3500KGS@500mm	3	1100mm
CP-XQ54G01B	5400KGS@500MM	4	1750mm



## Forward Bulk Bin Tipper

Designed to safely and efficiently handle and tip bins in various work environments. Powered by hydraulic systems, it lifts and tips bins forward, allowing for the easy and controlled disposal or transfer of contents.

**135 degrees tilting angle** ✓

**Self-lubrication bronze bushes** ✓

**Self-clamping, single pivot point, thick skid plate and helper ram for smoother tipping** ✓

Net Weight	Capacity	Dimensions	Suitable fork size	Suitable bin size
200kgs	1000kgs	1700mm x 800mm x 800mm	125mm x 45mm x 1100mm	1100mm-1200mm

# Hand Pallet Jack

---

Hand pallet jacks are typically designed with a hydraulic system that allows for the lifting and lowering of heavy loads. They consist of a pair of forks to slide under pallets, a handle for maneuvering, and wheels for easy movement.

Standard Pallet Jack Fork	Euro Pallet Jack Fork
Width 685mm x Length 1220mm	Width 550 mm x Length 1150mm
Total Life Height 188mm	
Lowered Fork Height 75mm	

- ✓ **2500KG Capacity**
- ✓ **Galvanized Pump, Polyurethane Wheel, PU Single Front Wheel**

